



BP PUMP

Applications:

- Cutting, turning, milling, boring, grinding and similar applications of the machine tools,
- Band sawing machines,
- Circulation systems. BP Pumps are used for pumping of cutting / cooling fluids.

On demand, BP Pumps can be supplied with inlet strainer.

Fluid Specifications:

- Coolants,
- Cutting oils,
- Grinding oils,
- Fluid temperature 0...60 °C
- Kinematic viscosity 1...45 mm²/s

Materials:

Pump body	: Aluminium
Volute	: Aluminium
Impeller	: Aluminium
Shaft	: Engineering steel - AISI 1040 (DIN C35) ,
Strainer	: PE (Optional)
Electric motor	: 3 phase induction motor 1 phase induction motor (Optional) 2 pole Protection degree IP 54

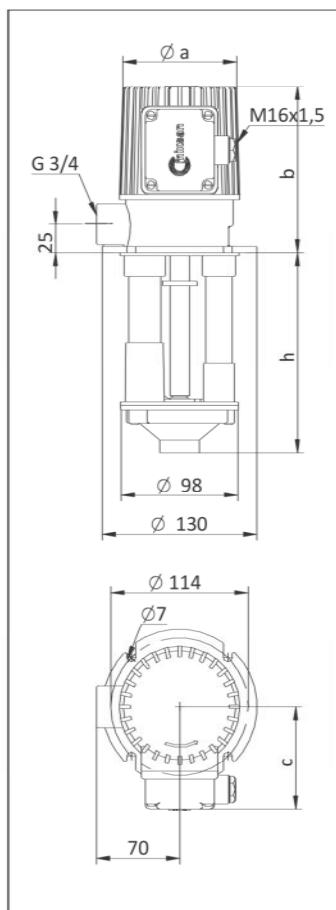

DIMENSIONS & NOMINAL VALUES

TYPE	Depth of immersion h (mm)	a	b	c	Weight kg	Power kW	Voltage V(Δ /Y)	Frequency Hz	Rated current A	Speed rpm
		mm								
BP/12	120	96	140	83	3.2	0.09	230/400	50	0.48/0.28	2830
BP/17	170				3.4					
BP/22	220				3.5					
BP/27	270				3.9					
BP/35	350				4.3					

* Pump dimensions according to EN 12157.

** The performance curves are based on $1 \text{ mm}^2/\text{s}$ (cSt) kinematic viscosity values and 997 kg/m^3 density

*** Curve tolerance according to ISO 9906:2012 Grade 3B .

Performance Curve

